

# ENGR 101 TEAM PROJECT

**ASSIGNED:**  
**Sept. 28-01**

**DUE:**  
**Oct. 12-01**

In this assignment you are to build some electronics and write some Keil c-51 code described below. Divide the tasks among your team.

## **Description:**

Your tracking device should wait on the 4 kHz signal from a beacon to commence emitting. After your device detects a signal, it will indicate in which of three positions the beacon is located. The position of the beacon will be determined by analyzing the signal present on two IR detectors. The three positions are left, center, and right. Center is defined as the direction that is approximately within  $\pm 10^\circ$  of straight ahead. Right and left are on either side of center. Your device will indicate the position by beeping as follows:

Left: Beeper on approximately .5 seconds and off approximately .5 seconds, repeating.

Right: Beeper on approximately .5 seconds and off approximately 1 second, repeating.

Center: Beeper on approximately 1 second and off approximately .5 seconds, repeating.

## **Software:**

The software should be written in modules. This way you can share the tasks between your team members. The modules you might need are discussed below:

### Main Module:

The main module is the module that defines the actual flow or logic of the overall project. The main module uses (calls) other functions (modules) to perform the required task. This module will contain a “while (1) loop”.

### Analog to Digital Module:

The Analog to Digital Module is the module that when called and passed a number between 0 and 7 will return the digital equivalent of the analog voltage present at the micro-controller board’s respective analog input.

### Wait Module:

The Wait Module reads the background IR emission and waits on the emission to increase before returning to the Main Module. When the detected IR emission is greater than approximately 5% to 10% of the background IR emission, the Wait Module will terminate allowing the Main Module to resume. The Wait Module uses (calls) the Analog to Digital Module to measure the IR emission.

### Sound Module:

The Sound Module will produce one cycle (an “on” period followed by an “off” period) when called by the Main Module. The sound module will produce the sound patterns for left, center, and right when passed the numbers 1, 2, and 3 respectively.

## Hardware:

The circuitry for a beacon needed to test your tracking device and the circuitry for the IR sensors are shown in fig. 1 and fig. 2 below:

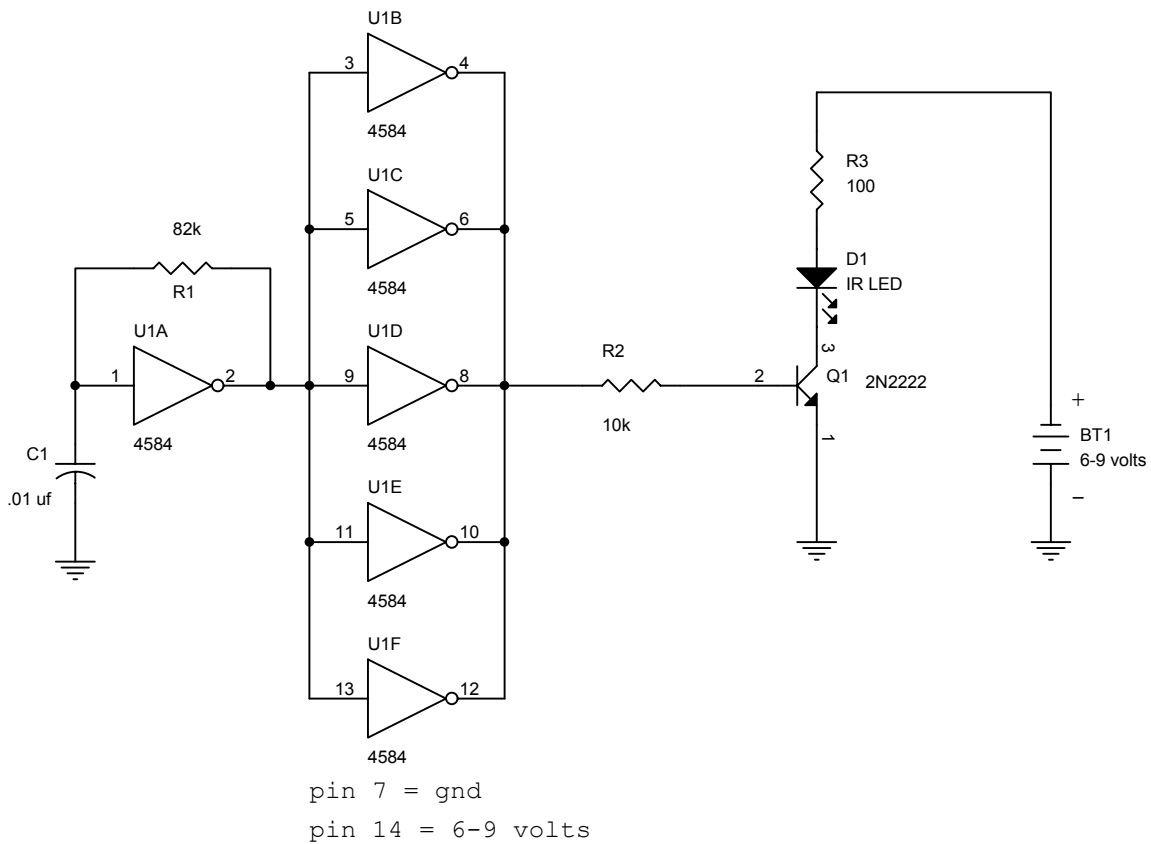

# FIG. 1 BEACON

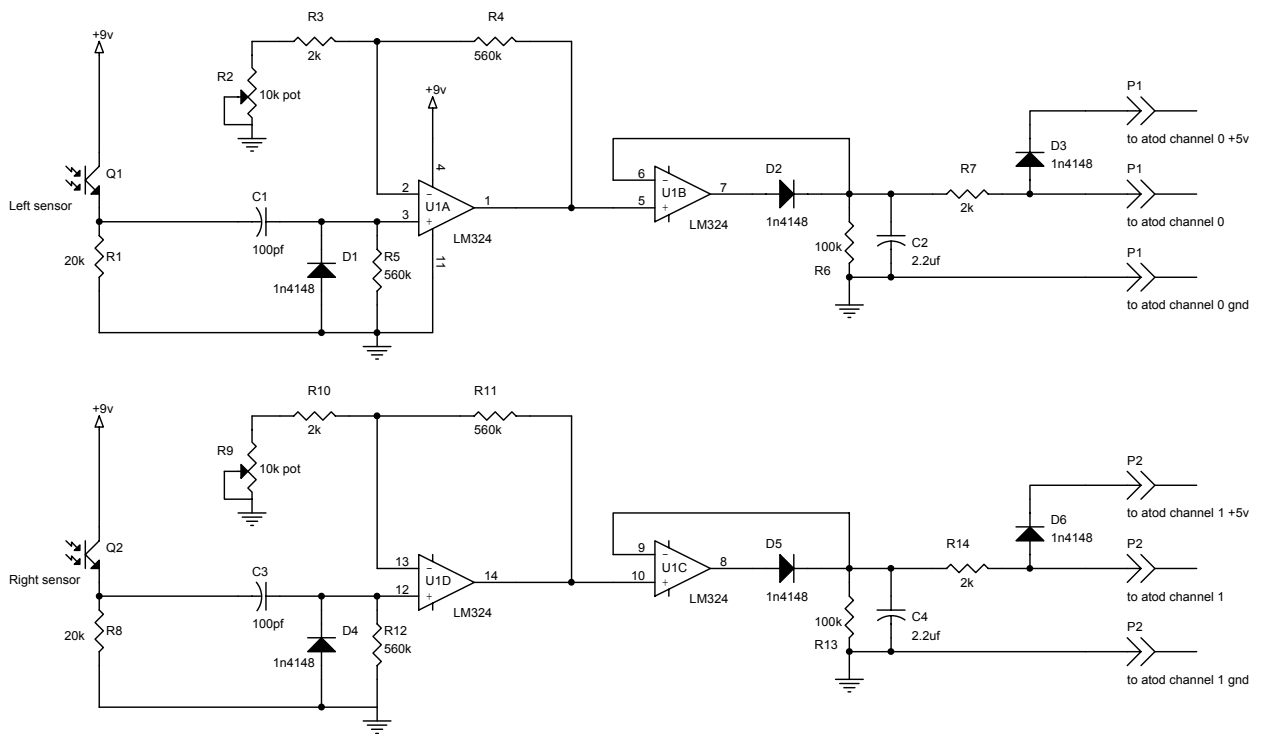

**FIG. 2 IR SENSOR CIRCUIT**